



MUSCLE WALL®

Specifications:

- Material
 - Low density polyethylene
 - Elongation to yield: 20%
 - Impact strength: 190 ft-lb
 - Tensile strength at yield: 2600 psi
- All Season Compatible
 - Temperature range: -40° F to 180° F
 - 10 year UV rated
- Portable
 - Weight per unit (empty): 110lbs
 - Weight per unit (filled): 1400lbs
 - Units nest together for transportation
- Ground Pressure
 - Empty: 0.0527 psi
 - Filled: 0.6705 psi
- Dimensions
 - Minimum polyethylene thickness: 0.25"
 - Footprint on ground: 14.5 ft²
 - 6 ft. wide x 2.54 ft. deep x 4 ft. high
 - Installed in 6 ft. sections
 - Fit 80 units on one 48 ft. flatbed trailer

4 Foot System

MUSCLEWALL®

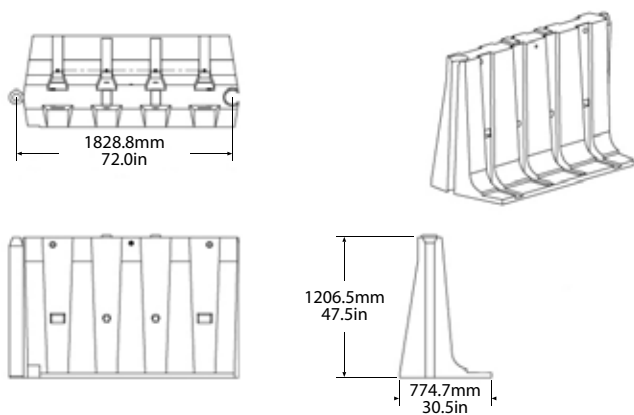

Features:

- Walls interconnect
- Connection acts like a hinge allowing for 22° of motion
- Corner piece allows 90° turns
- Ratchet straps restrain adjacent panels
- Tongue and groove panel interface for easy staking
- Patent Protected
 - US 8.313.265 B2
 - USD 631977
 - US 634443

Contact us:

Please contact us with any questions you have regarding Muscle Wall and how we can help you with your water management needs.

Email – info@musclewall.com

Toll-free – 1.800.801.8739

Fax – 435.514.6707

Mail – 675 North 600 West Suite 1

Logan, UT 84321

Web – www.musclewall.com